

ELVIS Experiment #1 –Equivalent Circuits

Introduction:

The National Instruments Educational Laboratory Virtual Instrumentation Suite (NI-ELVIS) is an integrated set of electronics hardware that can be used to quickly build circuits and measure their outputs. The circuits are built on a prototyping board that has attached power supplies and digital multi-meters. Throughout the quarter, ELVIS will be used to demonstrate some of the abstract principles taught in MAE 140, using real circuits.

The first experiment this quarter will test some properties of a simple circuit, and then verify that a Thévenin equivalent of circuit has these same properties. The simple circuit we will build will be a voltage divider, illustrated in Figure 1.

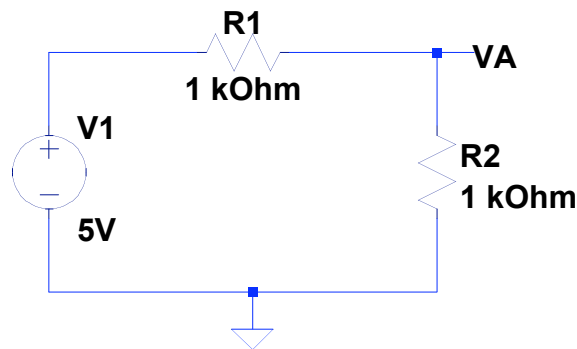

Figure 1: Circuit A, a simple voltage divider.

This circuit will be compared with its Thévenin equivalent, illustrated in Figure 2.

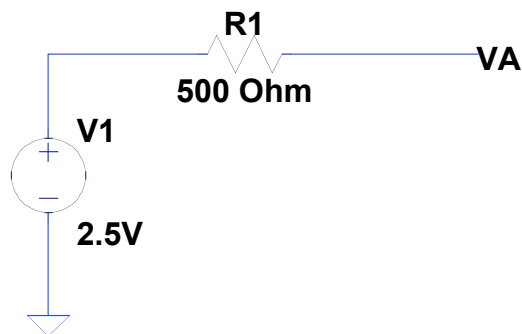

Figure 2: Circuit B, the Thévenin equivalent of Circuit A.

Circuit Analysis:

To compare the circuits, we will measure the voltage VA of both circuits and confirm that they are the same. We will then apply a load to Circuit A and Circuit B, and measure voltage VA on each circuit. The load will consist of two resistors in parallel, placed between VA and ground. The circuits with the load attached are diagrammed in Figure 3 and Figure 4, below.

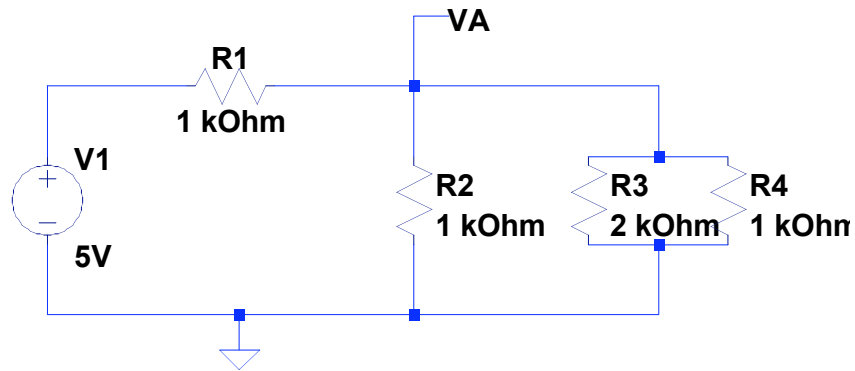

Figure 3: Circuit A with a load

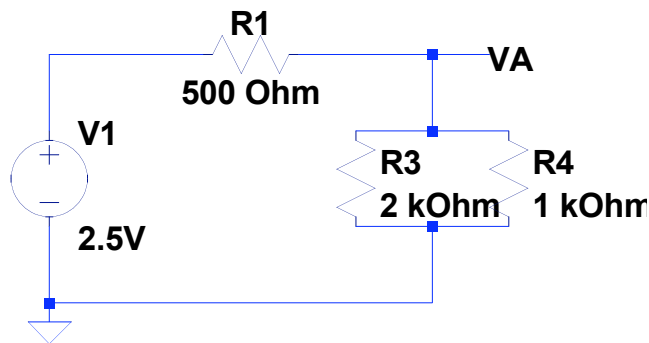

Figure 4: Circuit B with load

Circuit analysis predicts that **both** circuits should have a voltage $VA = 2.5V$ without the load, and $VA = 1.43V$ with the load attached. In this experiment these voltages will be measured, **showing that Circuit A and Circuit B really are equivalent circuits**, in that they respond to loads in the same way.

Implementation:

Prototyping boards (or “bread-boards”) are square grids that can be used to make temporary electrical connections, simply by inserting wires into the appropriate holes. Internally, the prototyping board makes a connection between all wires along each row. The columns designated by red and blue lines also are internally connected, and are commonly connected to a voltage source and to ground, respectively. On ELVIS, the prototyping board is extended on the sides to give access to built-in power supplies and measurement devices. This is illustrated in Figure 5, below.

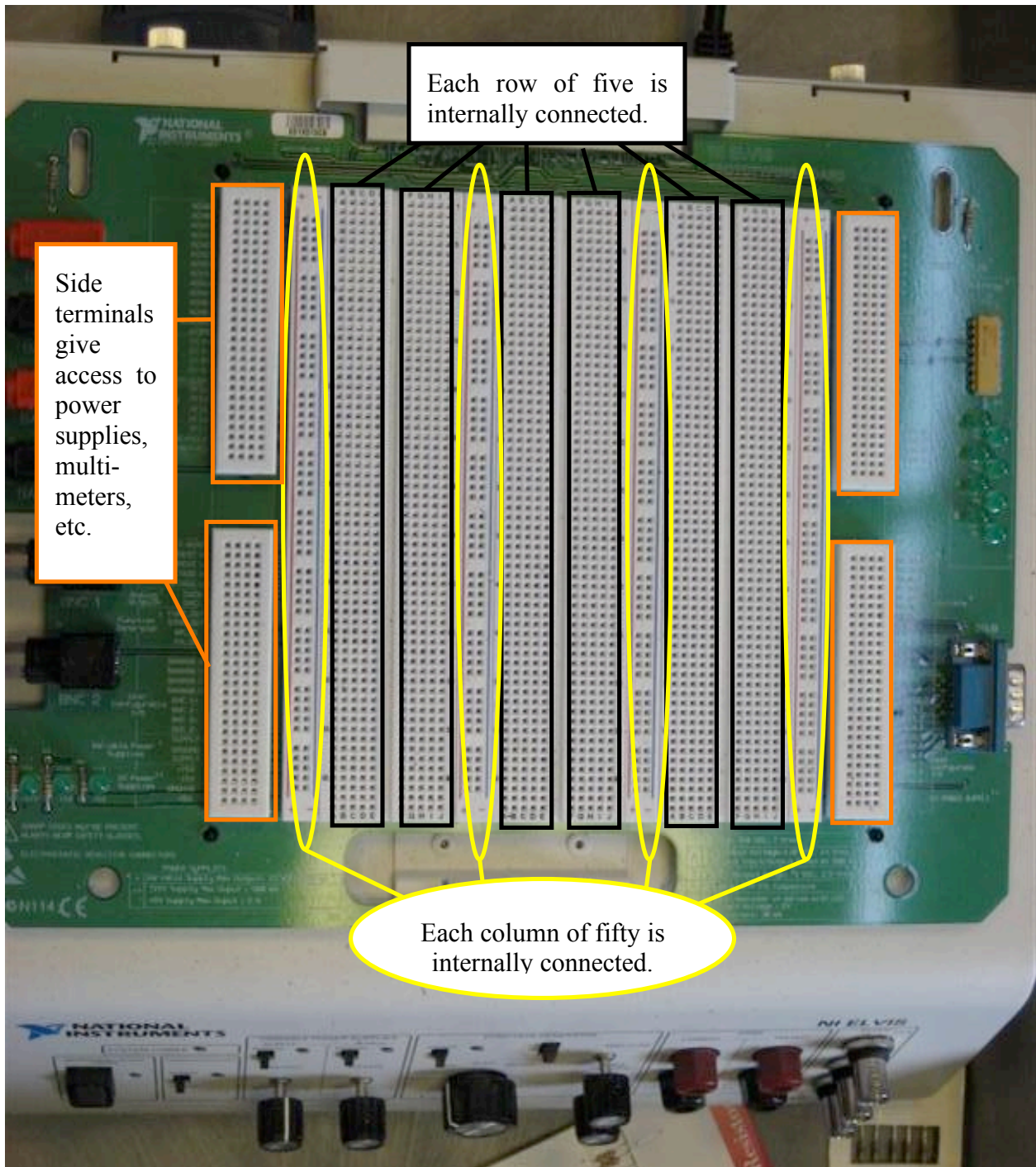

Figure 5: ELVIS prototyping board

Figure 6, below, shows the layout of Circuit A and Circuit B on the ELVIS prototyping board. Circuit A is constructed by connecting two 1 kOhm resistors in series between a 5 Volt supply and ground. The load is attached by placing the two load resistors in parallel between rows 36 and 39 of the prototyping board. Circuit B is constructed on the lower half of the board by connecting two 1 kOhm resistors in parallel between a 2.5 Volt supply and the load, which is in turn connected to ground. The two 1 kOhm resistors placed in parallel make an effective resistance of 500 Ohms, which is the Thévenin resistance called for by Circuit B.

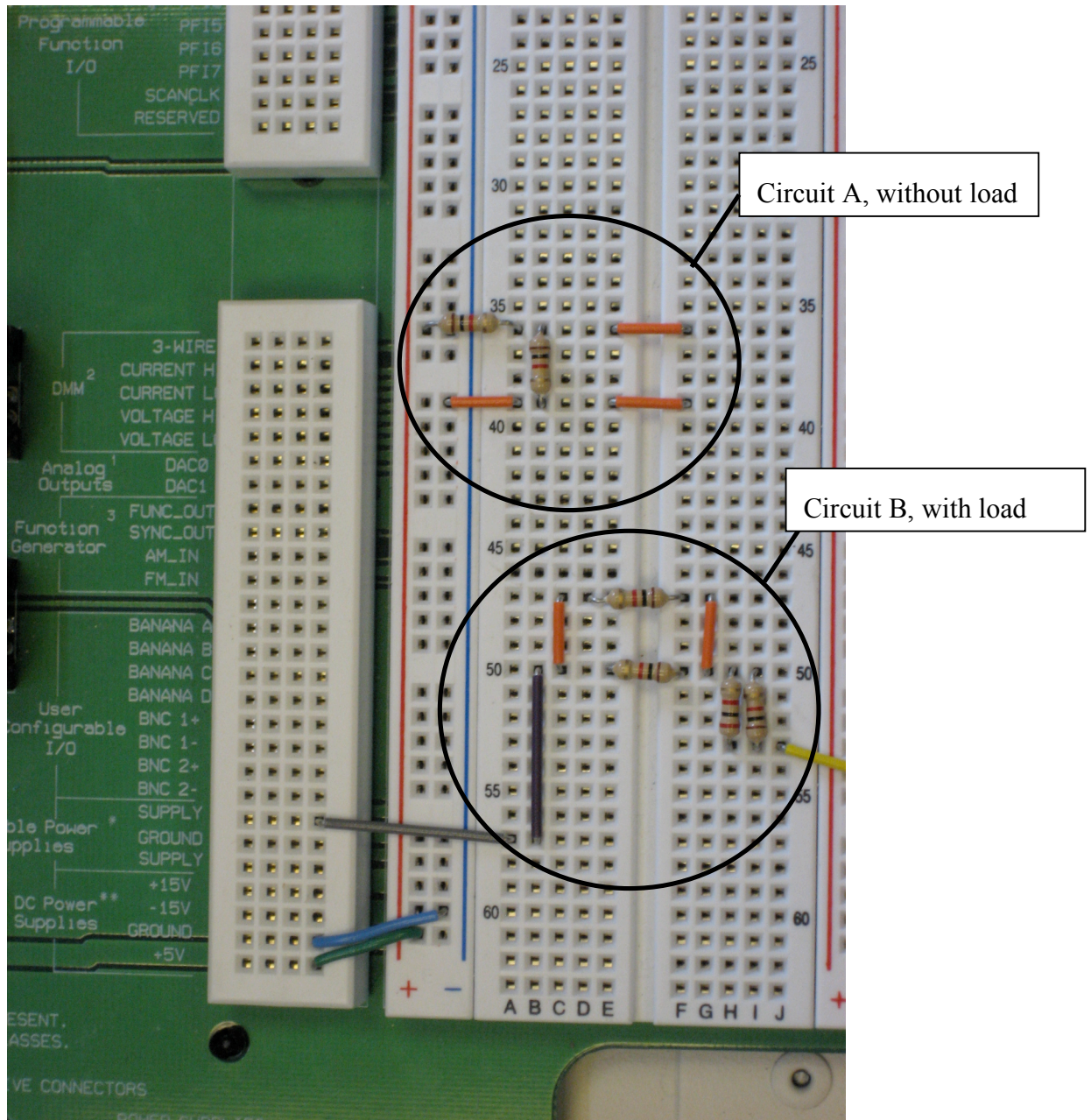

Figure 6: Circuit layout on ELVIS